

# Digital Load Cell Amplifier Unit Type DAS 72.1

PROGRAMMERS MANUAL - FILLER VERSION

Firmware Version 72.184 v2.xx

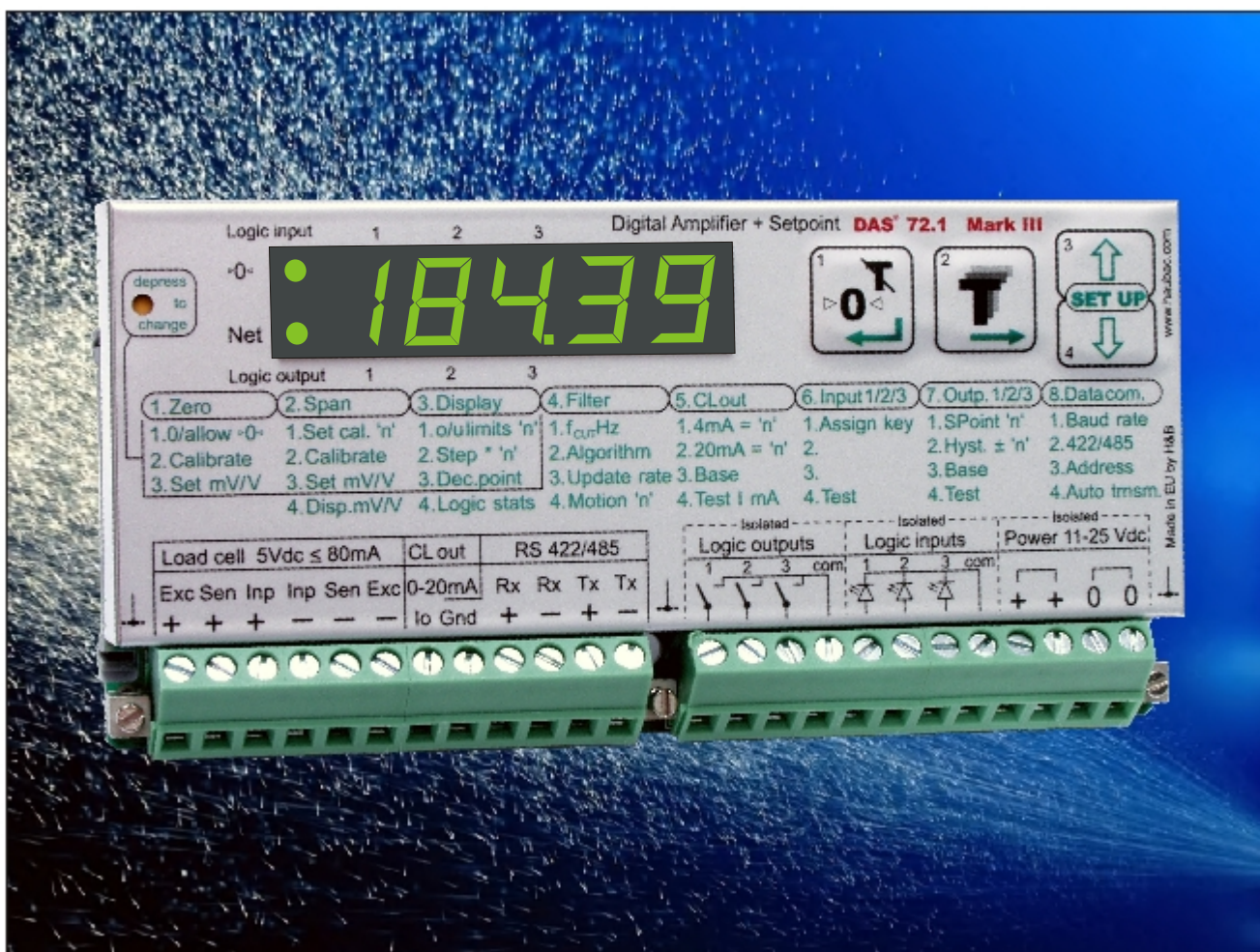

Website: [www.sensortechniques.com](http://www.sensortechniques.com) e-mail: [info@sensortechniques.com](mailto:info@sensortechniques.com)  
 Tel:+44 (0)1446 771185 Fax:+44 (0)1446 771186

---

1	INTRODUCTION & SPECIFICATIONS	3
2	COMMUNICATIONS & GETTING STARTED	4
2.1	Serial Interface	4
2.2	Command Language	4
2.3	Setup baud rate / device address	5
2.4	Getting Started	5
3	COMMUNICATION CONNECTIONS	6
3.1	RS422 4 Wire Point to Point Full Duplex	6
3.2	RS485 2 Wire Multi-drop Half Duplex	6
3.3	RS485 4 Wire Multi-drop Half Duplex	7
4	COMMANDS OVERVIEW	8
5	COMMANDS	11
5.1	System diagnostic Commands - ID, IV, IS, SR	12
5.2	Filling/Dosing Set up Commands - PD1-PD10, AC, SC, DI, GD, SD, UR	14
5.3	Calibration Commands - CE, CI, CM, DS, DP, CZ, CG, AZ, AG, ZT, FD, CS	20
5.4	Motion detection Commands - NR, NT	24
5.5	Filter setting Commands - FM, FL	25
5.6	Set Zero/Tare and Reset Zero/Tare Commands - SZ, RZ, ST, RT	27
5.7	Output Commands - GG, GN, GT, GS, GW	29
5.8	Commands for external I/O control - IN, IO, OM	31
5.9	Communication setup Commands - AD, CL, BR, DX, OP	33
5.10	Analogue Output setup Commands - AA, AL, AH	34
5.11	Save Cal., Setup & Analogue Output parameters - CS, WP, AS	35
6	CALIBRATION PROCEDURE	36
7	USE IN "APPROVED" APPLICATIONS (For Information Only)	37
8	SOFTWARE (FIRMWARE) DOWNLOADS	38
8.1	Firmware updates for the DAS 72.1	38
9	RS232/RS485 CONVERTER WIRING	39
9.1	4 Wire RS422 to RS232 (Point to Point)	39
9.2	2 Wire RS485 to RS232 (Multi-drop)	40
9.3	Transmitter turnaround delay	41

## 1 INTRODUCTION & SPECIFICATIONS

The Model DAS72.1 is a precise, high speed digital amplifier for filling and dosing applications. The DAS72.1 can be completely setup and calibrated using its on-board display and keyboard. Alternatively you can use a P.C. or PLC to setup and calibrate the DAS72.1 via its RS422 port. The DAS 72.1 features a full multi-drop communication capability and can be programmed using the straight forward ASCII command set.

The filler version of the DAS72.1 has 3 logic inputs which are pre-programmed to be the 'Start' filling cycle input, the 'Stop' filling cycle input and the 'Container in Place' input.

The 3 logic outputs are pre-programmed to be the 'Coarse' valve output, the 'Fine' valve output and the 'Ready'- filling cycle complete output.

A momentary high applied to the Start input will start the filling cycle provided that both the Stop and Container in Place inputs are also 'high'.

When filling starts both the Coarse and Fine outputs come on until the Coarse turnover point is reached. At this point the Coarse output turns off leaving the Fine fill on to trickle feed the product until the target weight is reached. Once the filling cycle is complete the Ready output comes on signifying that the cycle has finished and the DAS is ready to start again.

The industry standard 4-20mA analogue output can be used to drive a slave repeat display or taken into a PLC.

### Technical Specifications of the DAS 72.1:

Linearity	<0.002% Full Scale
Load Cell Excitation	5 V DC, load cell(s) input impedance 80-2000 Ohms, 6-wire technique
Analogue Input Range	±3.2 mV/V (bipolar, for push/pull weighing or tension/compression forces)
Minimum input per vsi	0.05µV per interval
Resolution	Internal ±260,000 counts, ± 18 bit A/D converter; external max ± 99,999 counts
Conversion rate	Internal 2400 measurements per second; external up to 600 measurements per second
Digital filter	FIR Filter 2.5 ... 19.7 Hz or IIR Filter 0.25 ... 18 Hz; each programmable in 8 steps
Calibration	Software calibration and set up
Computer Interface	RS485 or RS422 full duplex, 9600 ... 115200 Baud; up to 32 devices on a bus. (RS485)
Weighing functions	Zero, gross, tare, net, filter etc.
Filling/Dosing functions	Gross or Net Filling, manual or automatic Inflight compensation,
Analogue Output	0/4 .... 20mA or 0 ... 10V (special order)
Inputs	3 opto-isolated inputs, 10-30 VDC max. 3.5 mA (Start/Stop & CIP)
Outputs	3 opto-isolated outputs, <45 V DC/AC 1A (Coarse/Fine & Ready)
Temperature effects	On zero 5 ppm/°K typ.; max. <10 ppm/°K On span 4 ppm/°K typ.; max. <8 ppm/°K
Temperature range	-10°C to +50°C (compensated); -20°C to +60°C (storage)
Enclosure	Tin plated steel enclosure sealed to IP 40
Dimensions	135 x 66 x 19 mm, weight approx. 180 g
Power supply	11 ... 25 V DC ±10%, <3 W, galvanically isolated.
EMC/Approvals	CE 73/23/EEC; 93/98/EEC and 89/336/EEC

All dimensions in mm. Dimensions and specifications are subject to change without notice.

## 2 COMMUNICATIONS & GETTING STARTED

### 2.1 Serial Interface

Communication with the DAS 72.1 is via the RS422/RS485 port. The data format is the familiar 8/N/1 structure (8 data bits, no parity, 1 stop bit). The DAS 72.1 can communicate at the following baud rates: 9600, 19200, 38400, 57600, 115200 baud.

#### RS422

- ! Connection using a 4 wire technique.
- ! Point to Point connection i.e. no bus communication possible.

#### RS485

- ! Connection using 2 or 4 wire techniques
- ! Multi-drop connection possible with up to 32 DAS 72.1 on a bus.
- ! Half duplex only (DX=0).

#### (RS232)

- ! An optional RS422 to RS232 converter is available at extra charge

### 2.2 Command Language

The command set for the DAS 72.1 is based on a simple ASCII format. This consists of a 2 capital letter code which enables the user to setup the device, get results or check parameters.

Example:

A DAS 72.1 with the address or channel number 1 is connected via the RS485 port to a bus system. You want to get the net weight from this device.

In this manual a space is represented by “\_” and Enter (CR/LF) by “ ”

Master (PC / PLC) sends	Slave (DAS 72.1) responds	Status
OP_1		Open Device number 1
	OK	Device number 1 ready
GN		Get Net weight value
	N+123.45	Net weight value with sign & decimal point

The command OP\_2 opens the communication channel to device #2 and closes communication with device #1. Now device #2 acknowledges that it is active (OK) and responds to any commands on the bus. Communication with device #2 will be closed by another OP command (for another device on the bus e.g. OP\_5) or by the close command e.g. CL\_2.

Each OP\_X command implies a CL command to all other devices on the bus except #X. This makes the address structure easier and improves system performance.

### 2.3 Setup Baud rate / Device Address

The factory default baud rate is 9600 baud. The factory default device address is 0. Under normal circumstances the baud rate can be changed or viewed using the BR command (Page 31). Similarly, the device address can be changed or viewed using the AD command (Page 31). If for some unknown reason you are unable to communicate with the DAS, you can manually check these settings by going to section 8 of the menu using the front panel keys on the unit. Please note that with the address set to 0 the DAS will be set into continuously active mode, where the device will listen and respond to any command on the bus without the need for an OP xxx command. Also with a baud rate of 9600 baud only approximately 100 readings per second can be transmitted continuously. If you need to transmit more readings per second please select a higher baud rate.

### 2.4 Getting Started

You will require a:

- ! PC or PLC with either a RS422 or RS485 communication port
- ! If you are using a PC or PLC with an RS232 port, you will require a RS422 to RS232 converter (optional extra)
- ! Interconnecting cabling - See the wiring diagram on Page 6
- ! A load cell / scale with test weights or a load cell simulator
- ! A 12-24 V DC power supply capable of delivering approximately 150mA for each DAS and load cell
- ! One or more DAS72.1
- ! A suitable ASCII communication software\*

Refer to the wiring diagram on Page 6

\* You can easily communicate between a PC and the DAS using programs such as Hyperterminal (included in Windows)

Also the DOP software with graphical user interface and oscilloscope function is now available (Windows 2000/XP). Download the latest version of the DOP software from [www.haubac.com/DOP/dop.htm](http://www.haubac.com/DOP/dop.htm)

### 3 COMMUNICATION CONNECTIONS

#### 3.1 RS422 4 Wire Point to Point Connections Full Duplex

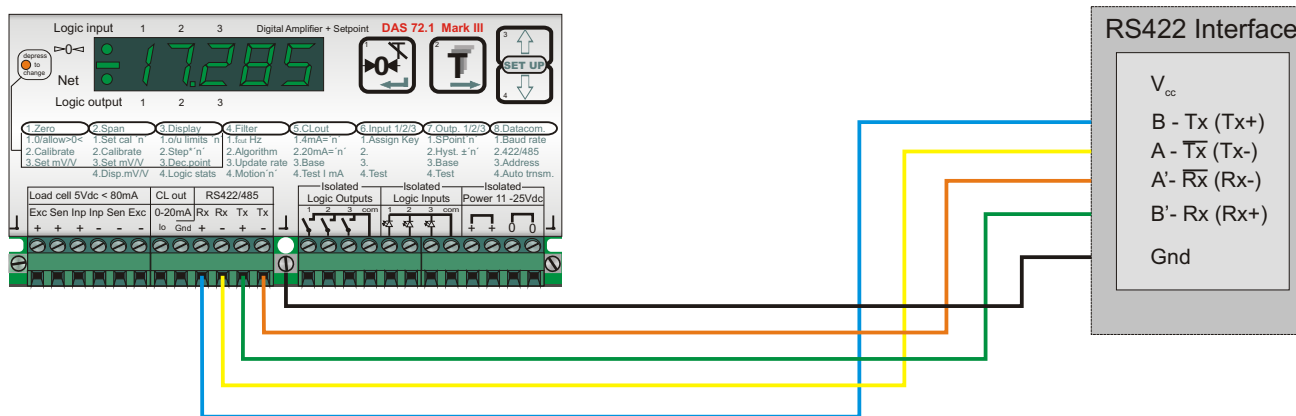

The standard interface on the DAS 72.1 is RS422. The Tx+ connection from the host system is connected to +Rx of the DAS 72.1. Similarly the Tx- from the host is connected to Rx -, the Rx- is connected to the Tx - and the Rx+ is connected to the Tx +. The shield connection for the RS422 cable should be connected to the ground terminal to the right of the RS422 port on the DAS72.1

#### 3.2 RS485 2 Wire Multi-drop Connections Half Duplex

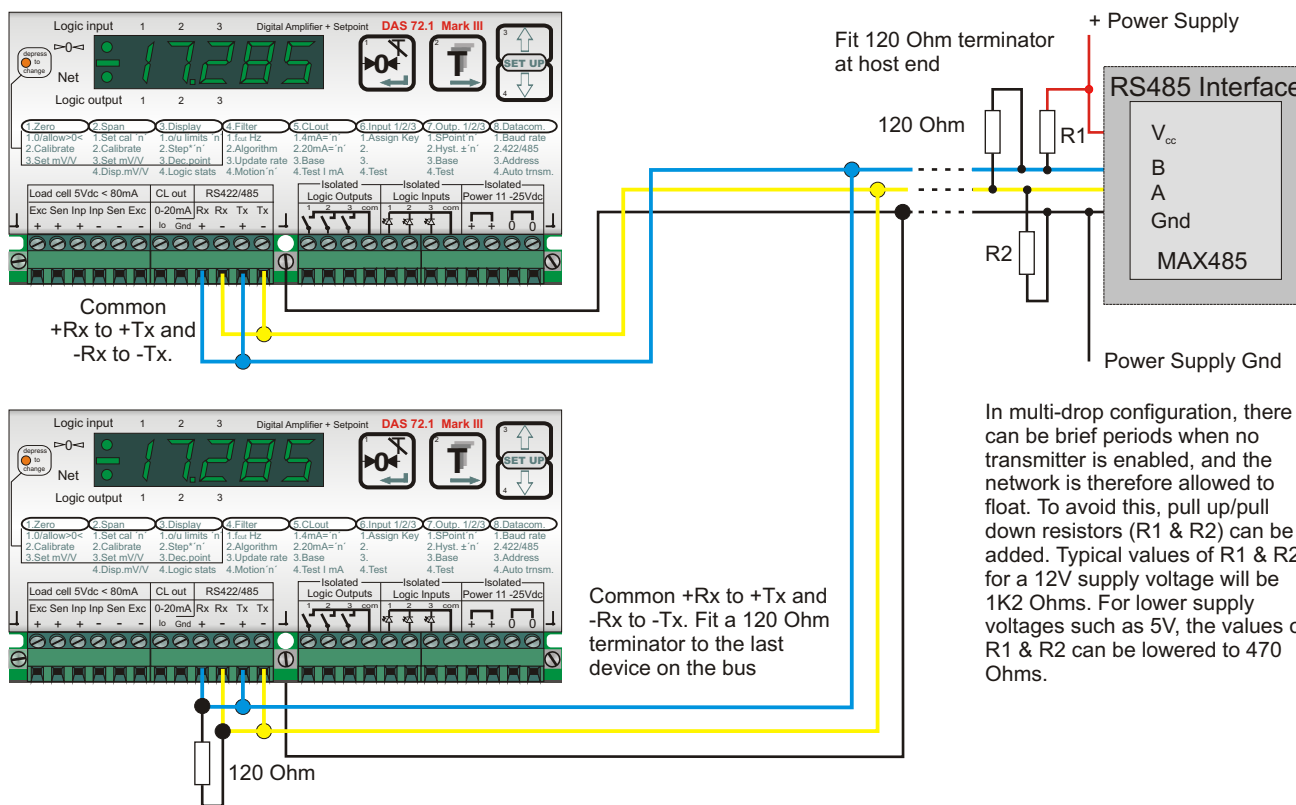

In multi-drop configuration, there can be brief periods when no transmitter is enabled, and the network is therefore allowed to float. To avoid this, pull up/pull down resistors (R1 & R2) can be added. Typical values of R1 & R2 for a 12V supply voltage will be 1K2 Ohms. For lower supply voltages such as 5V, the values of R1 & R2 can be lowered to 470 Ohms.

### 3.2 RS485 2 Wire Multi-drop Connections Half Duplex (continued)

The DAS 72.1 can be wired in a multi-drop mode where up to 32 devices can be connected to one bus. The +Rx and +Tx should be commoned together and should be connected to the B terminal of the host RS485 interface. The -Rx and the -Tx should similarly be commoned and connected to the A terminal of the host RS485 interface. The ground connection (GND) from the host RS485 should be connected to the ground terminal to the right of the RS422 port on the DAS72.1. Termination resistors of 120 Ohm each should be placed across the A/B lines at host end of the bus and across the A/B lines of the last device on the bus. In addition it may be necessary to add pull up and pull down resistors (R1 & R2) to the A/B lines to prevent these lines ‘floating’ during periods of no transmission. Where the supply voltage to the RS485 line driver IC is typically 5V DC for example, the value of R1 & R2 can be 470 Ohms each. Where for example you are using a RS232 to RS485 converter with a supply voltage of 12 V DC, the value of R1 & R2 should be increased to 1K2 Ohms (1200 Ohms).

### 3.3 RS485 4 Wire Multi-drop Connections Half Duplex (Recommended)

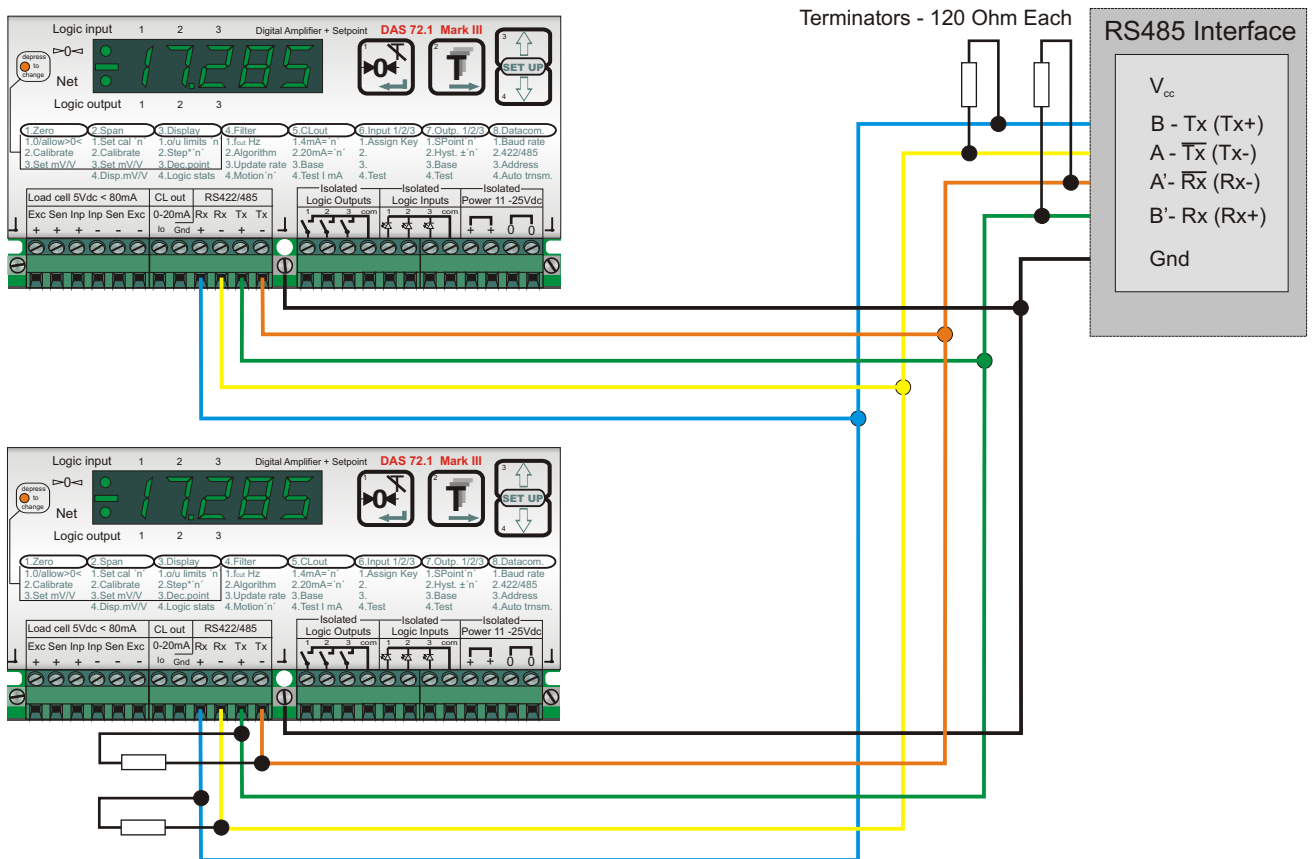

Terminators - 120 Ohm Each

The DAS 72.1 can also be wired in a 4 wire multi-drop mode where up to 32 devices can be connected to one bus. To achieve this simply parallel up all connections. So all Rx + terminals are connected together and are connected to the B (Tx +) terminal of the host RS485 interface. All Rx - terminals are connected together and connected to the A (Tx -) terminal of the host RS485 interface. All Tx + terminals are connected together and are connected to the B' (Rx+) terminal of the host RS485 interface. All Tx - terminals are connected together and connected to the A' (Rx -) terminal of the host RS485 interface. All ground connections are connected together and connected to ground connection on the host RS485. Terminating resistors (120 Ohms each) should be connected across each pair of wires both at the host end and on the last device on the bus.

## 4 COMMANDS OVERVIEW

Command	Short Description	Usage	Parameter Values	Full Description on
AA	Analogue Output base	Read or Set Analogue Output base	0 to 8	Page 34
AD	Network address	Read or Set the Network Address	0 to 255	Page 33
AG	Absolute Gain Calibration	Read or Set the Absolute Gain Calibration	± 32000	Page 22
AH	Analogue Output High Calibration	Read or Set the Analogue Output High Cal.	0 to 99,999	Page 34
AI	Set Action of Logic Inputs	Read or Set the Action of the Logic Inputs	0 to 15	Page 30
AL	Analogue Output Low Calibration	Read or Set the Analogue Output Low Cal.	0 to 99,999	Page 34
An	Get/Set Setpoint n base	Read or Change the Setpoint base	0 to 8	Page 33
AS	Save Analogue Output settings	Save the Analogue Output settings	none	Page 35
AZ	Absolute Zero Calibration	Read or Set the Absolute Zero Calibration	± 32000	Page 22
BR	Baud Rate	Read or Change the Baud Rate	9,600 to 115,200	Page 33
CE	Calibrate Enable - TAC Code	Allows access to important Cal/Set up parameters	0 to 65,535	Page 20
CG	Calibrate Gain (TAC protected)	Calibrate the weighing system span or gain	0 to 99,999	Page 22
CI	Close 'Open' devices (RS485 Multi-drop)	Read or Set the minimum output or display value	0 to -99,999	Page 20
CL	Close 'Open' devices (RS485 Multi-drop)	Closes all open communication paths (Multi-drop)	None	Page 33
CM	Calibrate Maximum (TAC protected)	Read or modify the maximum output value	0 to 99,999	Page 20
CS	Calibrate Save (TAC protected)	Save Calibration Parameters to EEPROM	None	Page 23 & 35
CZ	Calibrate Zero (TAC protected)	Calibrate the weighing system zero	None	Page 21
DP	Decimal Point (TAC protected)	Read or modify the decimal point position	0 to 5	Page 21
DS	Display Step Size (TAC protected)	Read or modify the display step size or increment	1 to 200	Page 21
DX	Duplex	Select half (0) or full (1) duplex	0 to 1	Page 33
FD	Factory Default	Reset to factory default settings	None	Page 23
FM	Filter Mode	Read or modify the filter mode	0 = IIR Filter / 1 = FIR Filter	Page 25
FL	Filter Level	Read or modify the filter level (strength)	0 to 8	Page 25
GA	Get Average Weight	Get the current 'average' weight value	None	Page 15
GG	Get Gross Weight Value	Get the gross weight value.	None	Page 29
GH	Get Hold Value	Get the Hold value	None	Page 38
GM	Get Peak	Get the Peak value.	None	Page 38
GN	Get Net Weight Value	Get the net weight value	None	Page 29
GO	Get Peak to Peak Value	Get the Peak to Peak value.	None	Page 39
GS	Get Sample (ADC value)	Get the ADC sample value.	None	Page 29
GT	Get Tare Value	Get the tare value	None	Page 29
	Get Valley Value	Get the valley value	None	Page 38
GW	Get 'Long' Weight Value	Get the 'Long' Weight Value	None	Page 29
Hn	Get/Set Hysteresis on Setpoint n	Read or modify the hysteresis value on Setpoint n	-99,999 to 99,999	Page 32

## 4 COMMANDS OVERVIEW (Continued)

Command	Short Description	Usage	Parameter Values	Full Description on
HT	Hold Time - Logic Outputs	Set a Hold Time for the Logic Outputs	None	Page xx
ID	Get Device Identity	Read the device identity	None	Page 12
IN	Read Status of Inputs	Read the status of the logic inputs	None	Page 31
IO	Read/Modify Output Status	Read or modify the status of the logic outputs	0000 to 0111	Page 31
IS	Get Device Status	Get the device status.	None	Page 12
IV	Get Firmware Version Number	Get the firmware version number	None	Page 12
LI	List the settings	List the DAS72.1 Settings	None	Page 34
MT	Measuring Time	The time over which the average value is derived	0 to 500 ms	Page 13
NR	No-motion Range	Read or modify the no-motion range	0 to 65,535	Page 24
NT	No-motion Time	Read or modify the no-motion time in msecs	0 to 65,535	Page 24
OM	Control of Logic Outputs by Host	Read or modify which logic outputs controlled by host	0 to 0111	Page 32
OP	Open connection	Open a connection to device number x	0 to 255	Page 33
Pn	Logic outputs action	Read or modify action of the logic outputs	0 to 1	Page 31
PD1	Logic outputs action	Read or modify the tare averaging time	0 to 65535	Page 14
PD2	Logic outputs action	Read or modify the coarse turnover point	0 to 99999	Page 14
PD3	Logic outputs action	Read or modify the blanking time	0 to 65535	Page 14
PD4	Logic outputs action	Read or modify the target fill weight (set point)	0 to 99999	Page 15
PD5	Logic outputs action	Read or modify the in-flight delay time	0 to 65535	Page 15
PD6	Logic outputs action	Read or modify the filled weight average time	0 to 65535	Page 15
PD7	Logic outputs action	Read or modify the in-flight correction factor	0 to 50	Page 16
PD8	Logic outputs action	Read or modify the display hold time	0 to 65535	Page 16
PD9	Logic outputs action	Read or modify the filling mode - Gross or Net	0 to 1	Page 16
PD10	Logic outputs action	Read or modify a fixed in-flight value	0 to 99999	Page 17
RM	Reset Peak, Valley, Hold, Peak to Peak	Resets the Peak, Valley, Hold & Peak to Peak values	None	Page 36
RT	Reset Tare	Cancel tare value - unit reverts to Gross weighing	None	Page 28
RZ	Reset system zero	Restores the calibration zero point	None	Page 27
SD	Save Dosing Setup Parameters	Save the filling/dosing set up parameters	None	Page 18
SG	Start auto transmitting gross weight	Start auto transmitting the gross weight value	None	Page 27
SH	Start auto transmitting Hold value	Start auto transmitting the Hold value	None	Page 36
SM	Start auto transmitting Peak value	Start auto transmitting the Peak value	None	Page 36
SN	Start auto transmitting net weight	Start auto transmitting the net weight value	None	Page 27
Sn	Get/Set the setpoint values	Read or modify the setpoint values	-99,999 to +99,999	Page 31
SO	Start auto transmitting Peak to Peak value	Start auto transmitting the Peak to Peak value	None	Page 37
SR	Software reset	Causes the DAS to perform a software reset	None	Page 12
SS	Save Setpoint Parameters	Save Setpoint Parameters to EEPROM	None	Page 36



## 5 COMMANDS

For better clarity, all commands are divided into groups as described on the following pages.

5.1	System diagnostic Commands - ID, IV, IS, SR	12
5.2	Filling/Dosing Set up Commands - PD1-PD10, AC, SC, DI, GD, SD, UR	14
5.3	Calibration Commands - CE, CI, CM, DS, DP, CZ, CG, AZ, AG, ZT, FD, CS	20
5.4	Motion detection Commands - NR, NT	24
5.5	Filter setting Commands - FM, FL	25
5.6	Set Zero/Tare/Zero Range & Reset Zero/Tare Commands - SZ, RZ, ST, RT	27
5.7	Output Commands - GG, GN, GT, GS, GW	29
5.8	Commands for external I/O control - IN, IO, OM	31
5.9	Communication setup Commands - AD, CL, BR, DX, OP	33
5.10	Analogue Output setup Commands - AA, AL, AH	34
5.11	Save Cal., Setup & Analogue Output parameters - CS, WP, AS	35

## 5.1 System diagnosis Commands – ID, IV, IS, SR

Use these commands to get the DAS 72.1 type, firmware version or device status. These commands are sent without parameters.

### ID Request of device identity

Master (PC / PLC) sends	DAS 72.1 responds
ID	D:7214

The response to this request gives the actual identity of the active device. This is particularly useful when trying to identify different device types on a bus.

### IV Request of firmware version

Master (PC / PLC) sends	DAS 72.1 responds
IV	V:0206

The response to this request gives the firmware version of the active device.

### IS Request device status

Master (PC / PLC) sends	DAS 72.1 responds
IS	S:067000 (example)

The response to this request comprises of two 3-digit decimal values, which can be decoded according to the table below:

Leftmost 3-digit value:		Rightmost 3-digit value:	
1	Signal stable	1	(not used)
2	Zero action performed	2	(not used)
4	Tare active	4	(not used)
8	(not used)	8	(not used)
16	(not used)	16	(not used)
32	Output 1 active	32	(not used)
64	Output 2 active	64	(not used)
128	Output 3 active	128	(not used)

For example the result S:067000 decodes as follows:

Signal Stable (no-motion)	1
Zero action	2
Output 2 active	64
<b>Total</b>	<b>67</b>

Please note that the bits that are not used are set to zero.

**SR Software Reset**

Master (PC / PLC) sends	DAS 72.1 responds
SR	OK

This command will respond with 'OK' and after a maximum of 400 ms perform a complete reset of the DAS. This has the same functionality as powering off and on again (hardware reset).

## 5.2 Filling/Dosing Set up Commands PD1-PD10, AC, SC, DI, GD, SD, UR

Note: All filling/dosing setups should be stored with the SD command before power off.

### PD1 Tare Averaging Time (Range 0 ... 65535 milliseconds)

Set the time (in milliseconds) over which the tare weight will be averaged before filling begins. Permitted values are 0 ... 65535 milliseconds. To check the current setting issue the command without any additional parameters. To change the setting issue the command with the additional parameter. See table below.

Master (PC / PLC) sends	DAS 72.1 responds	Result
PD1	P1:+00100	Tare Averaging Time set to 100 milliseconds
PD1_200	OK	Tare Averaging Time changed to 200 msec

Please note that if Menu point 7.09 or PD 9 is set to Gross filling, this parameter will be ignored. The factory default setting PD 1=0 [Tare Averaging Time = 0]. See Filling Cycle timing diagram on page 19

### PD2 Set Coarse Turnover Point (Range 0 ... 99999)

Set the coarse turnover point - the point at which the coarse output turns off leaving the fine fill until the fill is complete. Permitted values are 0 ... 99999. To check the current setting issue the command without any additional parameters. To change the setting issue the command with the additional parameter. See table below.

Master (PC / PLC) sends	DAS 72.1 responds	Result
PD2	P2:+00500	Coarse Turnover point set to 500 (g.. Kg )
PD2_800	OK	Coarse Turnover point changed to 800

Please note that if a target fill weight (set point) is entered in Menu 7.04 or PD4, the value of menu point 7.02 and PD2 will automatically be set to 80% of the set point. The factory default setting PD 2=0 [Coarse Turnover point = 0]. See Filling Cycle timing diagram on page 19

### PD3 Set Blanking Time (Range 0 ... 65535 milliseconds)

Set the blanking time in milliseconds, after the coarse fill has turned off. During this time, the weight value is temporarily ignored, the idea being to prevent the apparent weight (caused by the initial surge) exceeding the actual set point thus causing the system to switch off prematurely. Permitted values are 0 ... 65536. To check the current setting issue the command without any additional parameters. To change the setting issue the command with the additional parameter. See table below.

Master (PC / PLC) sends	DAS 72.1 responds	Result
PD3	P3:+00050	Blanking time set to 50 milliseconds
PD3_100	OK	Blanking time changed to 100 msec.

The factory default setting PD 3=0 [Blanking time = 0]. See Filling Cycle timing diagram on page 19

### PD4 Set the target Fill Weight (Set point) (Range 0 ... 99999)

Set the target fill weight (set point). Permitted values are 0 ... 99999. To check the current setting issue the command without any additional parameters. To change the setting issue the command with the additional parameter. See table below.

Master (PC / PLC) sends	DAS 72.1 responds	Result
PD4	P4:+01000	Target Fill Weight set to 1000 (g ... Kg)
PD4_500	OK	Target Fill Weight changed to 500 (g ..Kg)

Please note that if a target fill weight (set point) is entered in Menu 7.04 or PD4, the value of menu point 7.02 and PD2 will automatically be set to 80% of the set point. The factory default setting PD 4=0 [ Target Fill weight = 0]. See Filling Cycle timing diagram on page 19

### PD5 Set the In-flight delay time (Range 0 ... 65536 milliseconds)

Set the in-flight delay time (in milliseconds) after the fine fill output turns off. This delay allows any product that is in-flight (falling from the control valve after it has closed) to reach the container being filled. Permitted values are 0 ... 65536. To check the current setting issue the command without any additional parameters. To change the setting issue the command with the additional parameter. See table below.

Master (PC / PLC) sends	DAS 72.1 responds	Result
PD5	P5:+00100	In-flight delay time set to 100 milliseconds
PD5_125	OK	In-flight delay time changed to 125 msec.

The factory default setting PD 5=0 [ in-flight delay time = 0]. See Filling Cycle timing diagram on page 19

### PD6 Set the filled weight average time (Range 0 ... 65536 milliseconds)

Set the filled weight average time (in milliseconds). After the fill has been completed the final weight value is averaged over this time to get a more accurate result. Permitted values are 0 ... 65536. To check the current setting issue the command without any additional parameters. To change the setting issue the command with the additional parameter. See table below.

Master (PC / PLC) sends	DAS 72.1 responds	Result
PD6	P6:+00150	Filled Weight Average time set to 150 msec.
PD6_125	OK	Filled Weight Av. time changed to 125 msec.

The factory default setting PD 6=0 [ Filled Weight Average time = 0]. See Filling Cycle timing diagram on page 19

### PD7 Set the In-Flight correction factor (Range 0 ... 50%)

Set the in-flight correction factor (in percent). When the fill cycle is complete, the error between the actual filled weight and the target weight (set point) is calculated. This error is multiplied by the correction factor and the in-flight value is adjusted by this amount. Permitted values are 0 ... 50. To check the current setting issue the command without any additional parameters. To change the setting issue the command with the additional parameter. See table below.

Master (PC / PLC) sends	DAS 72.1 responds	Result
PD7	P7:+00015	In flight correction factor set to 15%.
PD7_12	OK	In flight correction factor changed to 12%

The factory default setting PD 7=0 [ In flight correction factor = 0]. See Filling Cycle timing diagram on page 19

### PD8 Set the Display Hold Time (Range 0 ..99999)

Set the display hold time in milliseconds. When the fill cycle is complete, the final fill weight can be held on the display for this time. Permitted values are 0 ... 99999. To check the current setting issue the command without any additional parameters. To change the setting issue the command with the additional parameter. See table below.

Master (PC / PLC) sends	DAS 72.1 responds	Result
PD8	P8:+01000	Display hold time set to 1 second
PD8_1500	OK	Display hold time changed to 1.5 seconds

The factory default setting PD 8=0 [ Display hold time = 0]. See Filling Cycle timing diagram on page 19

### PD9 Set Gross or Net Filling (Range 0 ...1)

Set whether the fill is Gross (0) or Net (1). In gross filling mode the target fill weight is the gross weight and takes no account of product build up or the weight of the container you are filling. In net filling mode, the weight of the container and any product build up is automatically tared out at the start of the filling cycle, giving a net fill equivalent to the target weight (set point). Permitted values are 0 or 1. To check the current setting issue the command without any additional parameters. To change the setting issue the command with the additional parameter. See table below.

Master (PC / PLC) sends	DAS 72.1 responds	Result
PD9	P9:+00001	Filling mode set to Net.
PD9_0	OK	Filling mode changed to Gross

The factory default setting PD 9=0 [ Gross filing = 0]. See Filling Cycle timing diagram on page 19

**PD10 Set a fixed in-flight value (Range 0 ...99999)**

Set a fixed in-flight correction value. When the fill cycle is complete, the error between the actual filled weight and the target weight (set point) is calculated and is known as the in-flight. If this error is repeatable it is possible to set a fixed in-flight value which adjusts the target fill weight by the same amount each time. Permitted values are 0 ... 99999. To check the current setting issue the command without any additional parameters. To change the setting issue the command with the additional parameter. See table below.

Master (PC / PLC) sends	DAS 72.1 responds	Result
PD10	P10:+00150	Fixed In flight value set to 150 (g ...Kg)
PD10_120	OK	Fixed In flight value changed to 120 (g.. Kg)

The factory default setting PD 10=0 [ Fixed In flight correction value = 0]. See Filling Cycle timing diagram on page 19

**AC Abort Filling Cycle.**

This command stops the filling cycle immediately and turns off all outputs. If the command is accepted the DAS 72.1 responds with 'OK'. If the command fails the DAS 72.1 responds with 'ERR'

**SC Start the Filling Cycle**

This command will start the filling cycle providing that the 'Stop' and 'Container in Place' electrical inputs are both high. If either of these inputs are low then the DAS72.1 will respond with 'ERR'.

**DI Read the Status of the Filling cycle and the logic outputs**

Issue this command to read the status of the filling cycle and the logic inputs

Master (PC / PLC) sends	DAS 72.1 responds
DI	I:70 (example)

The response to this request comprises of a 3-digit decimal value, which can be decoded according to the table below:

Response :	
1	Output 3 active (Ready)
2	Filling Cycle running
4	Container in Place Input high
8	(not used)
16	(not used)
32	(not used)
64	Output 2 active (Fine Fill)
128	Output 1 active (Coarse Fill)

For example the result I:70 decodes as follows:

Filling Cycle running	2
Container In Place Input high	4
Output 2 active (Fine Fill)	64
<b>TOTAL</b>	<b><u>70</u></b>

### GD Get the Last Dosed Weight

To check the value of the last dosed weight, issue the command without any additional parameters. See table below.

Master (PC / PLC) sends	DAS72.1 responds	Result
GD	D+01000	Last dosed weight was 1000 (g.....Kg)

### SD Save the filling/dosing setup parameters

With this command the value of the filling/dosing set up parameters (PD1-P10) will be saved in the EEPROM.

Master (PC / PLC) sends	DAS72.1 responds	Result
SD	OK	Parameter saved

### UR Update Rate

This command defines the number of measurements from the preceding IIR or FIR filter are used to calculate an average. Permitted values 0 .....7. Default value 0.

UR=0	1	2	3	4	5	6	7
1 sample	2 samples	4 samples	8 samples	16 samples	32 samples	64 samples	128 samples

To check the current setting issue the command without any additional parameters. To change the setting issue the command with the additional parameter. See table below.

Master (PC / PLC) sends	DAS72.1 responds	Result
UR	U+00001	Average value made up from 2 sample
UR_4	OK	Average value made up from 16 samples

# Filling Cycle

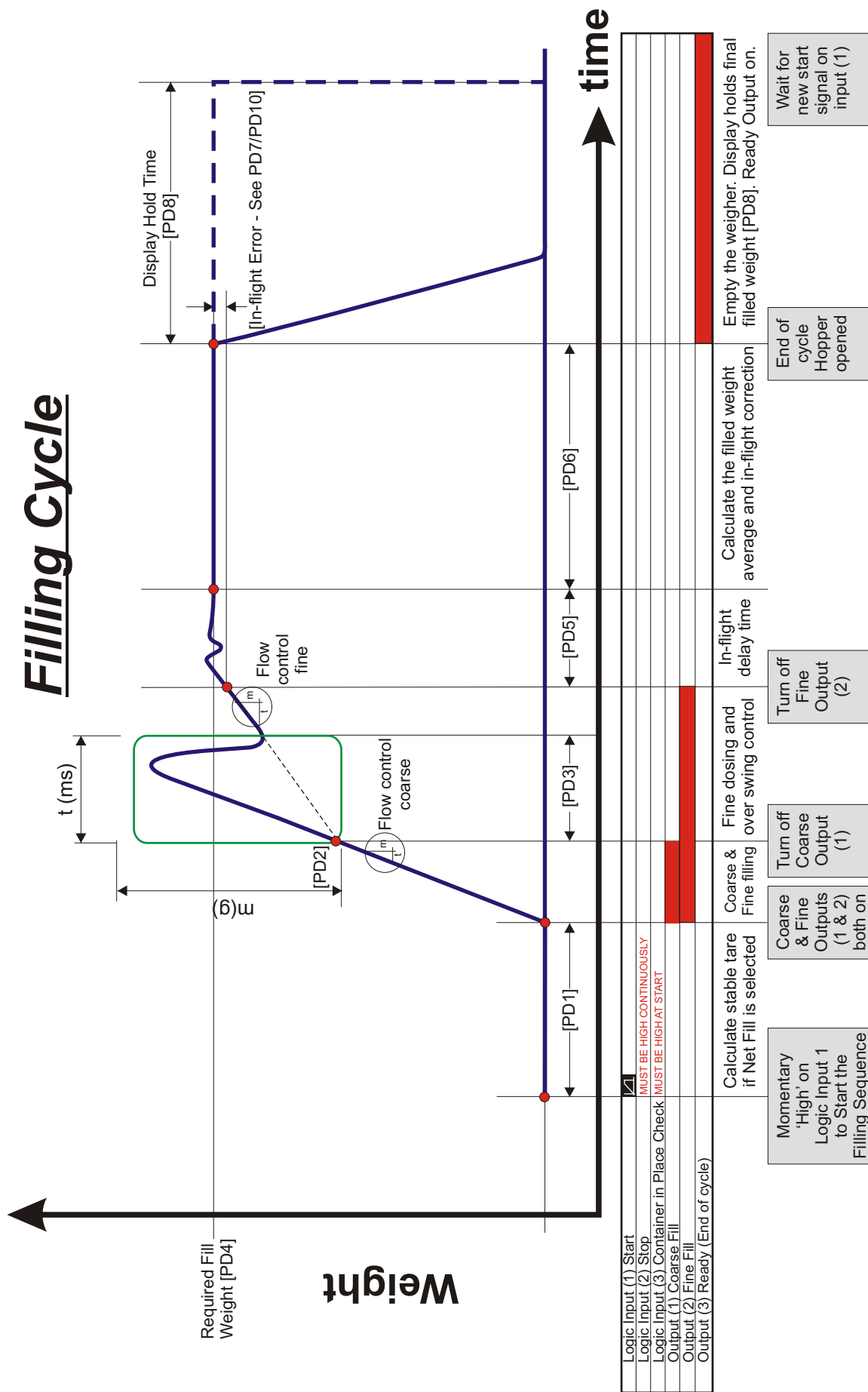

Logic Input (1) Start	Calculate stable tare if Net Fill is selected	Coarse & Fine Outputs (1 & 2) both on	Coarse & Fine Coarse Output (1)	Turn off Fine Output (2)	In-flight delay time	Calculate the filled weight average and in-flight correction	End of cycle Hopper opened	Wait for new start signal on input (1)
Logic Input (2) Stop								
Logic Input (3) Container in Place Check								
Output (1) Coarse Fill								
Output (2) Fine Fill								
Output (3) Ready (End of cycle)								

### 5.3 Calibration Commands CE, CM, DS, DP, CZ, CG, ZT, FD, CS

**Note:** TAC represents the Traceable Access Code (calibration counter) which increments every time new calibration data is stored. Calibration values are only stored in EEPROM when the CS command is issued (see CS command on Page 23)

#### CE TAC counter reading

With this command you can either read the current TAC value or enable a calibration command. To check the current TAC value issue the command without any additional parameters. To enable a calibration command, issue the CE command with the current TAC value. See table below.

Master (PC / PLC) sends	DAS 72.1 responds	Result
CE	E+00017 (example)	Current TAC value is 17
CE_17	OK	Calibration commands enabled

**This command MUST be issued PRIOR to any attempt to change calibration parameters such as CZ, CG etc.** In legal for trade applications the TAC value can be used to check if any critical parameters have been changed without re-verification. After each calibration the TAC counter increases by 1.

#### CI Set minimum output or display value

This command sets the minimum output or display value. Permitted values are between -99999 and 0. Factory default value CI = -9000. To check the current value issue the CI command without any additional parameters. To change the value of CI, issue the CE command with the current TAC value and then CI and the new setting. See table below.

Master (PC / PLC) sends	DAS 72.1 responds	Result
CI	I-00300	Current output minimum is set to -300
CE	E+00017 (example)	Current TAC value is 17
CE_17	OK	Calibration commands enabled
CI_-10000	OK	Output minimum changed to -10,000

The value of CI will determine the point at which the output/displayed value will change to “uuuuuu” signifying under-range.

#### CM Set maximum output or display value

This command sets the maximum output or display value. Permitted values are between 1 and 99999. Factory default value CM = 99999. To check the current value issue the CM command without any additional parameters. To change the value of CM, issue the CE command with the current TAC value and then CM and the new setting. See table below.

Master (PC / PLC) sends	DAS 72.1 responds	Result
CM	M+30000	Current output maximum is set to 30,000
CE	E+00017 (example)	Current TAC value is 17
CE_17	OK	Calibration commands enabled
CM_50000	OK	Output maximum changed to 50,000

CM continues on the next page .....

### CM Set maximum output or display value (Continued)

The value of CM will determine the point at which the output will change to “00000” signifying over-range.

Please note that the Set Zero (SZ) and the automatic Zero Track (ZT) functions are limited to  $\pm 20\%$  of the CM value.

### DS Set output reading step size

This command allows you to set different output reading step sizes. Permitted values are 1, 2, 5, 10, 20, 50, 100, and 200. Factory default value DS = 1. For example, if the step size is set to 2, then the output value will go up or down in 2s. To check the current step size, issue the DS command without any additional parameters. To change the value of DS, issue the CE command with the current TAC value and then DS and the new setting. See table below.

Master (PC / PLC) sends	DAS 72.1 responds	Result
DS	S+00002	Display step size is set to 2
CE	E+00017 (example)	Current TAC value is 17
CE_17	OK	Calibration commands enabled
DS_50	OK	Display step size changed to 50

### DP Set decimal point position

This command allows the decimal point to be positioned anywhere between the most and least significant digits. To check the current position, issue the DP command without any additional parameters. To change the decimal point position, issue the CE command with the current TAC value and then DP and the new setting. See table below.

Master (PC / PLC) sends	DAS 72.1 responds	Result
DP	P+00002	Decimal point is set to 2 places (xxx.xx)
CE	E+00017 (example)	Current TAC value is 17
CE_17	OK	Calibration commands enabled
DP_0	OK	Decimal point set to no places (xxxxx)

### CZ Set the calibration zero point

This command sets the calibration zero point which is a reference point for all weight calculations (TAC protected). To set a new calibration zero, issue the CE command with the current TAC value and then CZ (when there is no load applied). See table below. Factory default ~ 0mV/V input signal

Master (PC / PLC) sends	DAS 72.1 responds	Result
CE	E+00017 (example)	Current TAC value is 17
CE_17	OK	Calibration commands enabled
CZ	OK	New zero point saved

### CG Set calibration gain (Span)

This command sets the calibration span or gain which is a reference point for all weight calculations (TAC protected). To check the current gain calibration value, issue the CG command without any additional parameters. To change the calibration gain value, issue the CE command with the current TAC value and then CG (with the equivalent load applied). See table below.

Master (PC / PLC) sends	DAS 72.1 responds	Result
CG	G+10000	Calibration gain set at 10000 counts
CE	E+00017 (example)	Current TAC value is 17
CE_17	OK	Calibration commands enabled
CG_15000	OK	Calibration gain set to 15000 counts

For the best system performance, calibrate the gain (span) as near to the display maximum (CM) as possible. A minimum calibration load of at least 20% is recommended. Factory default calibration gain setting 20000 counts = 2.0000 mV/V input signal. Permitted values 0 - 99999

### AZ Absolute Zero Calibration

This command sets the calibration zero using the mV/V sensitivity of the weighing system (TAC protected). The mV/V reading of the weighing system at zero can be measured and calculated by dividing the signal value in mV by the Sense voltage in volts. Using this information you can set the zero accordingly. To check the current absolute zero calibration value, issue the AZ command without any additional parameters. To change the absolute zero calibration value, issue the CE command with the current TAC value and then AZ followed by the mV/V sensitivity (without the decimal point). See table below. Permitted values  $\pm 32,000$  counts ( $= \pm 3.2000$  mV/V). Factory default absolute zero calibration setting 0 counts = 0.0000 mV/V input signal.

Master (PC / PLC) sends	DAS 72.1 responds	Result
AZ	Z+0.0005	Calibration zero set at 0.0005 mV/V
CE	E+00017 (example)	Current TAC value is 17
CE_17	OK	Calibration commands enabled
AZ_00500	OK	Cal. zero point set @ 0.0500 mV/V

### AG Absolute Gain Calibration (Span)

This command sets the calibration span or gain using the mV/V sensitivity of the weighing system (TAC protected). From the load cell data sheet(s) the mV/V of the weighing system will be known. Using this information you can set the gain accordingly. To check the current gain calibration value, issue the AG command without any additional parameters. To change the calibration gain value, issue the CE command with the current TAC value and then AG followed by the mV/V sensitivity (without the decimal point) and then the number of counts you want displayed at that mV/V reading. See table below. Permitted values  $\pm 32,000$  counts ( $= \pm 3.2000$  mV/V). Factory default calibration gain setting 10000 counts = 2.0000 mV/V input signal.

Master (PC / PLC) sends	DAS 72.1 responds	Result
AG	G+2.0000	Calibration gain set at 2.0000 mV/V
CE	E+00017 (example)	Current TAC value is 17
CE_17	OK	Calibration commands enabled
AG_17500_10000	OK	Cal. gain set to 10000 counts @ 1.75 mV/V

## ZT Zero tracking

This command sets the zero tracking (TAC protected) window. To check the current zero tracking value, issue the ZT command without any additional parameters. To change the zero tracking window, issue the CE command with the current TAC value and then ZT followed by the new setting. See table below. Permitted values 0 (ZT disabled) to 255

Master (PC / PLC) sends	DAS 72.1 responds	Result
ZT	Z:005	Zero tracking window set to $\pm 5$ divisions
CE	E+00017 (example)	Current TAC value is 17
CE_17	OK	Calibration commands enabled
ZT 0	OK	Zero tracking disabled

Zero tracking will only be performed on values within  $\pm Y d$  of zero at a rate of  $0.4 d$  per second where  $d$  = display set size (see DS command) and  $Y$  is the zero tracking value set. The zero will only be tracked to a maximum of  $\pm 20\%$  of the display maximum (see CM command). Factory default: ZT = 0.

## FD Factory default settings

This command restores the DAS back to the original factory settings. The data will be written back into EEPROM and the TAC will be incremented by 1

Please note: All calibration and set up data will be lost if the FD command is issued !

Master (PC / PLC) sends	DAS 72.1 responds	Result
CE	E+00017 (example)	Current TAC value is 17
CE_17	OK	Calibration commands enabled
FD	OK	Factory default settings restored

## CS Save the calibration values

This command stores the calibration values in EEPROM and causes the TAC code to be incremented by 1. **If the CS command is not issued and the power to the DAS fails or is turned off, all changes to the calibration values will be lost.**

Master (PC / PLC) sends	DAS 72.1 responds	Result
CE	E+00017 (example)	Current TAC value is 17
CE_17	OK	Calibration commands enabled
CS	OK	Calibration values stored

The CS command saves all calibration group values as set by CZ, CG, CM, DS, DP and ZT. To do this issue the CE command with the current TAC code followed by CS.

### 5.4 Motion detection commands - NR, NT

The motion detection facility prevents certain functions from being performed if the weight value is unstable or 'in-motion'. This ensures that a new value cannot be set when the weight value is varying greatly over a short period of time. For a 'no-motion' or 'stable' condition to be achieved, the weight signal must not vary by more than NR divisions over the time period NT. If the weight signal is stable, the relevant bit of the 'Info status' (IS) response will be set.

The following functions are disabled if motion is detected:  
 Calibrate Zero (CZ), Calibrate Gain (CG), Set Zero (SZ) and Set Tare (ST)

#### NR No motion range

This command sets the range within which the weight signal can vary and still be considered 'stable'. Permitted values are between 0 and 65535. To check the current value, issue the NR command without any additional parameters. To change the value of NR, issue the NR command with the new setting. See table below. To save this change to EEPROM use the WP command.

Master (PC / PLC) sends	DAS 72.1 responds	Result
NR	R+00010	No motion range set to 10 d
NR_2	OK	No motion range changed to 2 d
WP	OK	Write parameter to EEPROM

With NR = 2, the weight signal can vary no more than  $\pm 2$  d, in the time period NT in order to be considered stable. Factory default : NR =1

#### NT No motion time

This command sets the time (in milliseconds) over which the weight signal is checked to see if it is 'stable' or has 'no-motion'. The weight signal has to vary by less than NR divisions over the time period NT, to be considered 'stable'. Permitted values are between 0 and 65535. To check the current value, issue the NT command without any additional parameters. To change the value of NT, issue the NT command with the new setting. See table below. To save this change to EEPROM use the WP command.

Master (PC / PLC) sends	DAS 72.1 responds	Result
NT	T+01000	No motion time set to 1000 ms
NT_500	OK	No motion time changed to 500 ms
WP	OK	Write parameter to EEPROM

With NT = 500, the weight signal can vary no more than  $\pm$  NR divisions, in the 500 ms in order to be considered stable. Factory default : NT = 1000 milliseconds.

## 5.5 Filter setting commands - FM, FL

Using the commands FM and FL, a digital filter type and strength can be set which will eliminate most unwanted disturbances. Please note that these filters are positioned immediately after the A/D converter and therefore affect all aspects of the weighing operation.

### FM Filter mode FIR / IIR

This command allows you to select the filter mode. Permitted values are 0 (IIR) or 1 (FIR). To check the current setting, issue the FM command without any additional parameters. To change the FM setting, issue the FM command with the new setting. See table below. To save this change to EEPROM use the WP command. Factory default FM = 0 (IIR)

Master (PC / PLC) sends	DAS 72.1 responds	Result
FM	M+00001	Filter mode set to FIR
FM_0	OK	Filter mode changed to IIR
WP	OK	Write parameter to EEPROM

The digital IIR filter works as a 2nd order low pass filter with a Gaussian characteristic damping at 40dB/decade. This gives a slower response to a step input with little or no overshoot. See table - Mode 0. For this filter mode, the update rate is not affected by the filter level.

The digital FIR filter also works as a low pass filter which has a quick response with some overshoot. For damping characteristics see table - Mode1. With this filter mode the update rate is dependant on the filter level

### FL Filter Level (Cut off frequency)

This command allows you to select the filter level or cut off frequency. Permitted values are between 0 to 8. To check the current setting, issue the FL command without any additional parameters. To change the FL setting, issue the FL command with the new setting. See table below. To save this change to EEPROM use the WP command. Factory default FL = 3

Master (PC / PLC) sends	DAS 72.1 responds	Result
FL	F+00003	Filter level set to 3
FL_1	OK	Filter level changed to 1
WP	OK	Write parameter to EEPROM

If FL= 0 is selected in either filter mode 0 or 1, the digital filter will be disabled

**Mode 0 Characteristic (IIR-Filter)**

FL	Settling time to 0.1% (ms)	3dB Cut-off frequency (Hz)	Damping @300Hz (dB)	Update-rate (samples/s)
1	55	18	57	600
2	122	8	78	600
3	242	4	96	600
4	322	3	104	600
5	482	2	114	600
6	963	1	132	600
7	1923	0.5	149	600
8	3847	0.25	164	600

**Mode 1 Characteristic (FIR-Filter)**

FL	Settling time to 0.1% (ms)	3dB Cut-off (Hz)	20dB damping at frequency (Hz)	40dB damping at frequency (Hz)	Damping in the stopband (dB)	Stopband (Hz)	Update rate (samples/s)
1	47	19.7	48	64	>90	>80	600
2	93	9.8	24	32	>90	>40	300
3	140	6.5	16	21	>90	>26	200
4	187	4.9	12	16	>90	>20	150
5	233	3.9	10	13	>90	>16	120
6	280	3.2	8	11	>90	>13	100
7	327	2.8	7	9	>90	>11	85.7
8	373	2.5	6	8	>90	>10	75

### 5.6 Set Zero/Tare and reset Zero/Tare commands - SZ, RZ, ST, RT

The following commands allow you to set and reset zero and tare values. The zero set during calibration remains the 'true zero' but a new 'current zero' can be set using the SZ command. If the SZ command is issued and accepted then all weight values will be based in the new 'current zero'. Please remember that the zero value will be subject to the Zero Tracking function if enabled.

If the weight signal is not stable (as defined by the No motion range NR and the No motion time NT) then both the set zero (SZ) and the set tare (ST) commands will be disabled.

Also the set zero (SZ) command is not allowed if the new zero value required and the 'calibration zero' differ by more than the value set by the ZR command.

See chapter 8 "Legal for trade" applications

#### SZ Set Zero

This command sets a new "current zero" which is then the basis of all weight values until further updated by the zero tracking function, another SZ command or the "reset zero" command (RZ). The SZ command will fail (DAS responds with ERR) if the difference between the new "current zero" and the "true zero" set during calibration is greater than (+ or -) the value set by the Zero Range (ZR) command. The SZ command will also fail if the weight signal is not stable, as defined by the no motion range (NR) and no motion time (NT). If the weight signal is "stable", the response to the IS (device status - see page 11) command will show the "signal stable" bit active and the SZ command will be accepted (OK). If the signal stable bit is not active, the SZ command will be rejected and the DAS will respond will ERR (error).

Master (PC / PLC) sends	DAS 72.1 responds	Result
SZ	OK	New zero set

The SZ command is issued without any parameters and will return either the OK or ERR response. If the SZ command is accepted, the DAS responds with OK and the "zero action performed" bit of the device status (IS) response will be active (1).

#### RZ Reset Zero point

This command cancels the SZ command and the zero reading reverts to that set by the CZ command during calibration.

Master (PC / PLC) sends	DAS 72.1 responds	Result
CZ	OK	Zero reverts to calibration zero (CZ)

The RZ command is issued without any parameters and will return either the OK or ERR response. If the RZ command is accepted, the DAS responds with OK and the "zero action performed" bit of the device status (IS) response (see page 11) will not be active (0).

## ST Set Tare

This command will activate the net weighing function by storing the current weight value as a tare.

The weight signal must be “stable” within the limits set by the no motion range (NR) and the no motion time (NT) for the set tare command to be accepted and the “signal stable” bit of the device status response (IS) to be active. (1)

Master (PC / PLC) sends	DAS 72.1 responds	Result
ST	OK	New tare set

The ST command is issued without any parameters and will return either the OK or ERR response. If the ST command is accepted, the DAS responds with OK and the “zero action performed” bit of the device status (IS) response will be active (1).

## RT Reset tare

This command cancels the tare and returns the weighing into gross mode.

Master (PC / PLC) sends	DAS 72.1 responds	Result
RT	OK	Tare deactivated

The RT command is issued without any parameters and will return either the OK or ERR response. If the RT command is accepted, the DAS will respond with OK and the “tare active” bit of the Device Status (IS) response will be set to 0

## 5.7 Output commands

The following commands “Get” the Gross, Net, Tare and ADC sample values from the DAS.

### GG Get Gross weight value

This command gets the gross weight value.

Master (PC / PLC) sends	DAS 72.1 responds	Result
GG	G+01.100	Gross weight value = 1.100 divisions

### GN Get Net weight value

This command gets the net weight value.

Master (PC / PLC) sends	DAS 72.1 responds	Result
GN	N+01.000	Net weight value = 1.000 divisions

### GT Get Tare value

This command gets the tare weight value.

Master (PC / PLC) sends	DAS 72.1 responds	Result
GT	T+0.100	Tare value = 0.100 divisions

### GS Get ADC sample value

This command gets the actual Analogue to Digital Converter (ADC) value. This can be useful during development or when calibrating to see how much of the ADC range is being used.

Master (PC / PLC) sends	DAS 72.1 responds	Result
GS	S+125785	ADC value = 125785 counts

For service applications it may be helpful to note the value of ADC at no load and full load.

### GW Get the ‘Long’ weight value

This command gets the ‘long’ weight value. The GW command is issued without any parameters and the response is a single string in the format **W+00100+011005109** which contains the current net weight, the current gross weight, the status values and a checksum. The first two sections of the returned string contains the net weight and the gross weight values followed by two hexadecimal characters which represent two bitmapped status indicators. The last two hexadecimal characters represent the checksum, which is the inverse of the sum of all the ASCII values of the string, not including the checksum characters.

GW Get the ‘Long’ weight continues over the page ....

**GW Get the ‘Long’ weight value (Continued)**

W	+00100	+01100	6	1	09
---	--------	--------	---	---	----

Leading character signifies response to GW command	Net Weight Excluding Decimal point	Gross Weight Excluding Decimal point	First bitmapped binary value	Second bitmapped binary value	Checksum
--	------------------------------------	--------------------------------------	------------------------------	-------------------------------	----------

First bitmapped binary value:		Second bitmapped binary value:	
0	not used	1	Signal stable (No Motion)
2	Output 1 active	2	Zero action performed
4	Output 2 active	4	Tare active
8	Output 3 active	0	not used

The checksum is derived as follows:-

- a) Add together the ASCII values of all 15 characters in the string
- b) Convert the decimal result to hexadecimal.
- c) Remove the most significant digit from the hexadecimal result
- d) Invert the remaining hexadecimal value
- e) Convert the hexadecimal value to characters.

### 5.8 Commands for external I/O control - IN, IO, OM

The DAS 72.1 has 3 independent logic inputs and 3 independent solid state outputs. The inputs and outputs can be configured and controlled completely via the DAS. The logic inputs can be read directly by the host application or can be used as remote control inputs for the zero and tare buttons etc. The 3 solid state outputs have additional control features which allow the user total control over the configuration and action of each output channel. The outputs are usually controlled internally via the setpoint commands but can be configured to be controlled externally by using the IM command.

The following group of commands allows the status of the 3 logic inputs to be read or modified and the logic outputs to be configured for internal or external control.

#### IN Read the status of the logic inputs

This command is sent without any parameters and reads the status of the logic inputs. The response is in the form of a 4 digit code where 0= false and 1 = true (inputs are active 'high'), the least significant bit corresponding to logic input 1 etc .

Master (PC / PLC) sends	DAS 72.1 responds	Result
IN	IN:0001	Input 1 active
IN	IN:0010	Input 2 active
IN	IN:0101	Input 1 & Input 3 active

#### IO Read/Modify the status of the output channels

With this command you can read the status of the logic outputs. The outputs are normally internally controlled by the filling software. The outputs can however be controlled by the host system **if they have been enabled by the OM command**. If the IO command is issued without any parameters the response shows the status of the logic outputs in the form of a four digit code where 0 = false and 1 = true (outputs are normally open, open drain MOSFETs), the least significant bit corresponding to Output 1 etc.

#### Request

Master (PC / PLC) sends	DAS 72.1 responds	Result
IO	IO:0001	Output 1 active
IO	IO:0010	Output 2 active
IO	IO:0101	Output 1 & Output 3 active

Please note that the status of the logic outputs is normally determined by the internal setpoint (see section 5.10) and therefore setting the logic output status using the IO command is not allowed **unless enabled by the OM command**. The status of the outputs can then be changed by issuing the IO command followed by the appropriate 4 digit code. For example if IO 0001 was sent to the DAS, the output 1 will be activated (FET conducting).

#### Setting

Master ( PC / PLC ) sends	DAS 72.1 responds	Result
IO_0001	OK	Output 1 active
IO_0010	OK	Output 2 active
IO_0011	OK	Output 1 & 2 active

## OM Control of the logic outputs by the host application

The logic outputs can be controlled by the host application (as opposed to the normal internal setpoints) if they are enabled by the OM command and the appropriate 4 digit code. If this command is issued without any parameters, the response shows which of the logic output are enabled. The response is in the form of a 4 digit code where 0= internal control and 1 = external control, the least significant bit corresponding to logic output 1 etc .

### Request

Master (PC / PLC) sends	DAS 72.1 responds	Result
OM	OM:0001	Output 1 Enabled
OM	OM:0010	Output 2 Enabled
OM	OM:0101	Output 1 & Output 3 Enabled

To enable the logic outputs to be controlled by the host application the OM command must be issued together with a 4 digit code. A "1" bit in the code enables the corresponding logic output to be controlled by the host application using the IO command. A "0" in the code leaves the corresponding logic output controlled by the internal setpoint. Logic output 1 is again the least significant bit.

### Setting

Master (PC / PLC) sends	DAS 72.1 responds	Result
OM_0001	OK	Enable Output 1
OM_0010	OK	Enable Output 2
OM_0101	OK	Enable Output 1 & Output 3

Note: When reading the status of the logic outputs using the IO command, the setpoint status will be returned regardless of the OM setting. Sending OM 0000 disables the external logic output control. Factory default:- OM= 0000

## 5.9 Communication setup Commands – AD, CL, BR, DX, OP

NOTE: These settings will only take effect after a power on reset (remember to store the settings using the WP command before turning the power off)

### AD Device address setup / request

Setting the device address to 0 will cause the device to be permanently active, listening and responding to every command on the bus without the need for an OP command. Factory default: Address 0

#### Request / Set device address

Master (PC / PLC) sends	DAS 72.1 responds	Result
AD	A:000	Address set to 0
AD_49	OK	Address changed to 49

### CL Close Device address n

Master (PC / PLC) sends	DAS 72.1 responds	Result
CL_3	OK	Device 3 closed

### BR Request / Setup Baud Rate

With this command, the following Baud rates can be set up: 9600, 19200, 38400, 5760 and 115200 baud. Factory default: 9600 Baud

Master (PC / PLC) sends	DAS 72.1 responds	Result
BR	B_9600	Baud rate set to 9600
BR_115200	OK	Baud rate changed to 115K2 baud

### DX Half or full duplex communication

With this command the communication can be set to half (DX=0) or full (DX=1) duplex.

Master (PC / PLC) sends	DAS 72.1 responds	Result
DX	X:000	Half duplex set
DX_1	OK	Communication changed to full duplex

Half duplex communication can be used for 2 wire RS485 communication. The auto transmit commands SG, SN & SW will only work if full duplex (DX=1) is selected. Factory default DX=0

### OP Device communication enable / request

This command, if sent without parameters, requests the address or device number of the device active on the bus. If sent with parameters, this enables the device defined by the parameters.

#### Request / Enable device communication

Master (PC / PLC) sends	DAS 72.1 responds	Result
OP	O:0003	Device 3 open
OP_14	OK	Device 14 opened

The requested device acknowledges its readiness and responds to all bus commands until a further OP command arrives with a different device address or a CL command is received.

## 5.10 Analogue Output Set Up Commands – AA, AL, AH

The changes to the following settings must be saved in EEPROM using the AS command.

### AA Sets which source the analogue output is based on.

You can select which source the analogue output follows. Please see table below.

	Analogue Output based on
AA = 0	Gross Weight
AA = 1	Net Weight
AA = 2	Analogue Output is OFF

### Request / Set Analogue Output Source

To check the current Analogue Output Source, issue the AA command without any additional parameters. To change the Analogue Output Source, issue the AA command and the new setting. See table below. Factory default AA = 1.

Master (PC / PLC) sends	DAS 72.1 responds	Result
AA	A+00001	Analogue Output follows the Net Weight
AA_0	OK	Analogue Output follows the Gross Weight

### AL Sets the analogue output Low Level (4 mA)

To check the current number of divisions at which 4 mA is sent, issue the AL command without any additional parameters. To change the number of divisions at which 4 mA is sent, issue the AL command and the new setting. See table below. Factory default AH = 00000.

Master (PC / PLC) sends	DAS 72.1 responds	Result
AL	L+00000	Analogue Output is 4 mA @ 0 d
AL_00500	OK	Analogue Output is 4 mA @ 500 d

### AH Sets the analogue output High Level (20 mA)

To check the current number of divisions at which 20 mA is sent, issue the AH command without any additional parameters. To change the number of divisions at which 20 mA is sent, issue the AH command and the new setting. See table below. Factory default AH = 10000.

Master (PC / PLC) sends	DAS 72.1 responds	Result
AH	H+10000	Analogue Output is 20mA @ 10000 d
AH_5000	OK	Analogue Output is 20mA @ 5000 d

## 5.11 Save Cal., Setup & Analogue Output parameters- CS, WP, SD, AS

The setup and calibration parameters can be divided into 4 groups:

Calibration parameters: CZ, CG, DS, DP & ZT are saved by the CS command.

Setup parameters (other than filling): FL, FM, NR, NT, BR, AD, DX etc. are saved by the WP command.

Filling Parameters: PD1-PD10 are saved by the SD command.

Please note that the calibration parameters can only be saved if the TAC code is known and precedes the CS command. **See the CE and CS commands on pages 20 & 23 respectively.**

Both the setup parameters and the filling parameters are stored in EEPROM using the WP and SD commands respectively.

The analogue output parameters are stored to EEPROM using the AS command.

### WP Save the setup parameters

With this command the settings of the Filter (FL, FM), the No-motion (NR, NT) and communication (AD, BR, DX) will be saved in the EEPROM.

Master (PC / PLC) sends	DAS 72.1 responds	Result
WP	OK	Parameter saved

### SD Save the filling/dosing setup parameters

With this command the value of the filling/dosing set up parameters (PD1-P10) will be saved in the EEPROM.

Master (PC / PLC) sends	DAS72.1 responds	Result
SD	OK	Parameter saved

### AS Save the Analogue Output setup parameters

With this command the values of the Analogue Output set up parameters (AA, AL, AH) will be saved in the EEPROM.

Master (PC / PLC) sends	DAS72.1 responds	Result
AS	OK	Parameter saved

## 6 CALIBRATION PROCEDURE.

The calibration interface features a “TRACEABLE ACCESS CODE” (TAC), which is required for use in “Approved” applications (see section 7, “USE IN APPROVED APPLICATIONS” for more details). This feature also ensures that there is no inadvertent or unauthorized access to the calibration parameters. The following parameters are considered as CALIBRATION commands:

- CE            Calibration Enable - returns the current TAC value.
- CZ            Calibrate zero - sets the system zero point
- CG            Calibrate gain - sets the system gain
- CM            Calibrate maximum - sets the maximum allowable display value.
- DS            Display step size - sets the output incremental step size.
- DP            Display decimal point - sets the position of the output decimal point
- ZT            Zero track enable.
- FD            Factory default settings (return to)
- CS            Calibration save

### Example: setup of zero point, gain and decimal point.

The chosen test weight has the value equivalent to 5000 increments. This could be 500 g, 5kg or 5000 kg. We will calibrate with a 500 g weight. The decimal point is set to 1 place using the DP command. So although the CG value (5000) does not contain a decimal place the final result does (500.0).

Master ( PC / PLC ) sends	DAS72.1 responds	Result
CE	E+00017	Request: TAC-counter CE = 17
CE_17	OK	Calibration sequence active
Scale no load !		
CZ	OK	System zero point saved
CE_17	OK	Calibration sequence active
Put calibration weight on (500 g) !		
CG_5000	OK	Setting span
CG	G+05000	Request: span 5000 d
CE_17	OK	Calibration sequence active
DP_1	OK	Setting: decimal point 0000.0
CE_17	OK	Calibration sequence active
CS	OK	Save calibration data in EEPROM

Zero point, gain and decimal point position were saved in the EEPROM; the calibration counter (TAC) is increased automatically by 1.

## 7 USE IN “APPROVED” APPLICATIONS (FOR INFORMATION)

The term “approved” applies whenever the weighing application is intended to be used for “legal for trade” weighing - that is, money will change hands according to the weight result. Such applications are bound by the legal metrology regulations of the relevant governments around the world, but most countries will comply with either the relevant ENs (Euro Norms) or the relevant OIML (Organization Internationale de Metrologie Legale) recommendation

Although the DAS 72.1 is not currently approved, other models in the Sensor Techniques range, such as the LDU78.1 are approved as components for use in weighing systems according to OIML recommendation R76. The LDU78.1 has a Class III, 5000 divisions approval issued by the Danish Electronics, Light & Acoustic (DELTA) and the approval certificate number is DK0199-R76-02.02 Revision 1, dated 30.07.03. This approval will allow the use in approved weighing throughout Europe and many other countries in the World.

To achieve approval on a particular application, it will be necessary to satisfy the relevant Governmental Trading Standards Authority that the requirements of the various rules and regulations have been satisfied. This task is greatly simplified if the key components of the weighing system, namely the load cells and the weighing indicator or digitiser, are already approved as “components”.

Usually, a discussion with the Weighing Equipment Approvals Officers at the relevant National Weights & Measures Office will then reveal the extent of any pattern testing that may be necessary to ensure compliance.

### **Restrictions upon usage when in “Approved” applications**

A number of performance restrictions come into force in Approved applications. These restrictions are the number of display divisions, which become limited to 5000 divisions, and the sensitivity per display division, which becomes 0.7uV per division.

Once installed in the application, an “approved” application will require “stamping” by an Officer of the relevant Governmental Trading Standards Department. This certifies the equipment or system as being in accordance to the relevant regulations and within calibration limits.

### **The Traceable Access Code (TAC)**

The user software must then provide a guard against improper access of the calibration commands (see the “Calibration Commands” section). The DAS72.1 like the LDU 78.1 digitiser features the “Traceable Access Code” or TAC method of controlling the access to the calibration commands group. This means that a code is maintained within the device, and is incremented whenever any change to any of the calibration commands is saved.

When performing the “stamping” test, the Trading Standards Officer will make a note of the TAC, and advise the user that any change to this code which occurs prior to the regular re-inspection by the Trading Standards Office, will result in legal prosecution of the user.

The user software is required as a condition of approval, to make the TAC available to the weight display indicator or console, on demand.

## 8 SOFTWARE (FIRMWARE) DOWNLOAD

To download new firmware into the DAS 72.1, you will require a Windows PC with an RS232 port and an RS232 to RS422/485 converter. .

### 8.1 Firmware update for DAS 72.1

This procedure applies to MK III hardware with firmware versions 2.xx or higher.

To upgrade the DAS 72.1 firmware you will require the H&B Programmer software together with the firmware you want to install. Please contact Sensor Techniques to obtain the latest versions.

Connect the DAS 72.1 to an appropriate power supply and PC

Check that you can communicate with the DAS72.1 using the DOP program (download the latest version from [www.haubac.com](http://www.haubac.com)) or Hyperterminal. Once you know you can communicate close either the DOP or Hyperterminal program to release the comms port.

Open the H&B Programmer and select the appropriate comms port to which the DAS is connected.

Click 'Detect' and the program will search the port for various device addresses/ baud rates.

When found the target type should be 'DAS 72 III'

Click on 'File' and select 'Open'. Select the firmware required.

Click 'Program'

A blue bar indicates the progress and the DAS 72.1 display shows 'FLASH'

At the end of the download a 'Success' message will be shown. Click OK to clear.

Close the H&B Programmer.

Turn off the power to the DAS 72.1

Turn the power to the DAS 72.1 whilst holding down the recessed enable switch.

Continue holding the recessed enable switch down until the DAS 72.1 goes into weighing mode after the display check finishes. (This resets the unit to the factory defaults).

## 9 RS232/RS485 CONVERTER WIRING

### 9.1 4 Wire RS422 to RS232 (Point to Point)

The following example shows how to wire up a DAS 72.1 to an RS232 port of a PC using an RS232 to RS422 converter (Amplicon 485F9). This circuit has been tested and is known to work correctly. The RS232 to RS422 converters can be purchased from Sensor Techniques or direct from Amplicon.

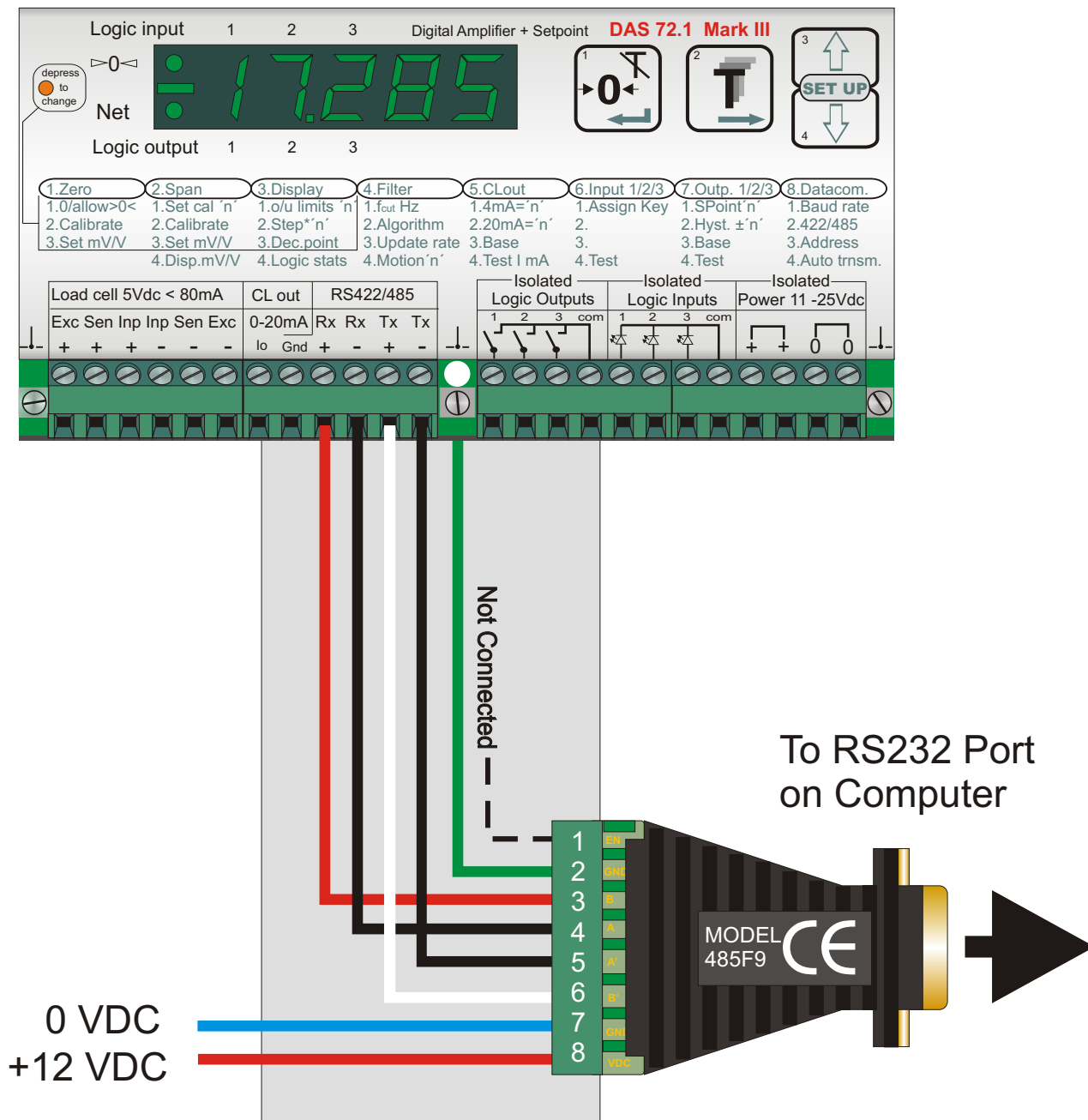

## 9.2 2 Wire RS485 to RS232 (Multi-drop)

The following example shows how to wire up 2 or more DAS 72.1s in a multi-drop application to an RS232 port of a PC using an RS232 to RS485 converter (Amplicon Magic 485F9). This circuit has been tested and is known to work correctly. The RS232 to RS485 converters can be purchased from Sensor Techniques or direct from Amplicon. The transmitter turnaround time of magic 485F9 converter must be set to 4uS by cutting all 3 links between the pads of J2 (on pcb of converter). See Section 9.3. Please note that the DAS72.1 must be set to half duplex (DX = 0) when used in this configuration.

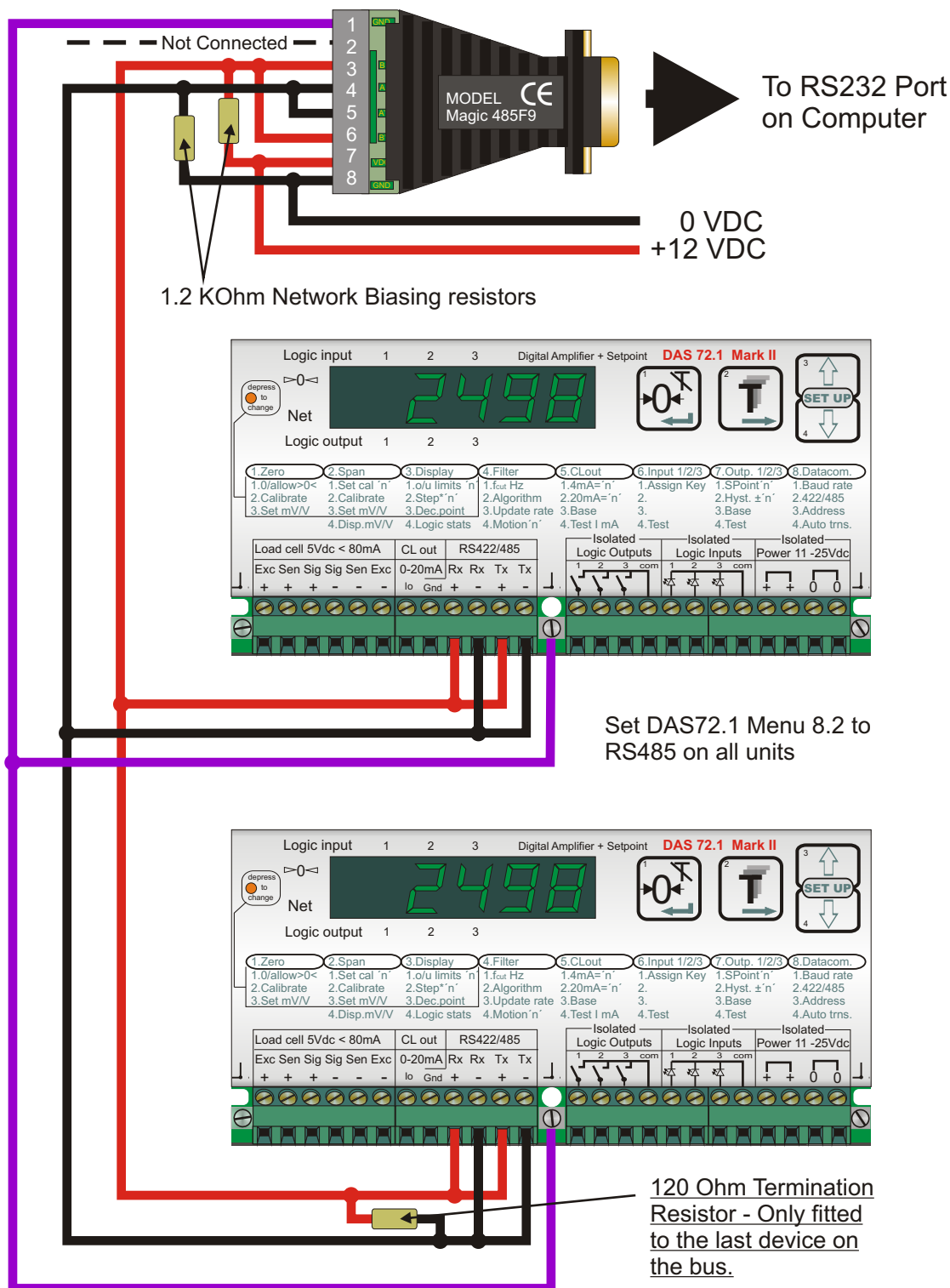

### 9.3 Transmitter Turnaround Delay

By the nature of the operation of this unit, there will be a time delay in switching the unit from transmit to receive. This time is set by Amplicon to 512 us as a default. This delay is too long and the response to a command sent to the DAS will be corrupted or truncated. To prevent this, set the turnaround time to the minimum (4us) by cutting all 3 links between the pads of J2 (on converter pcb).

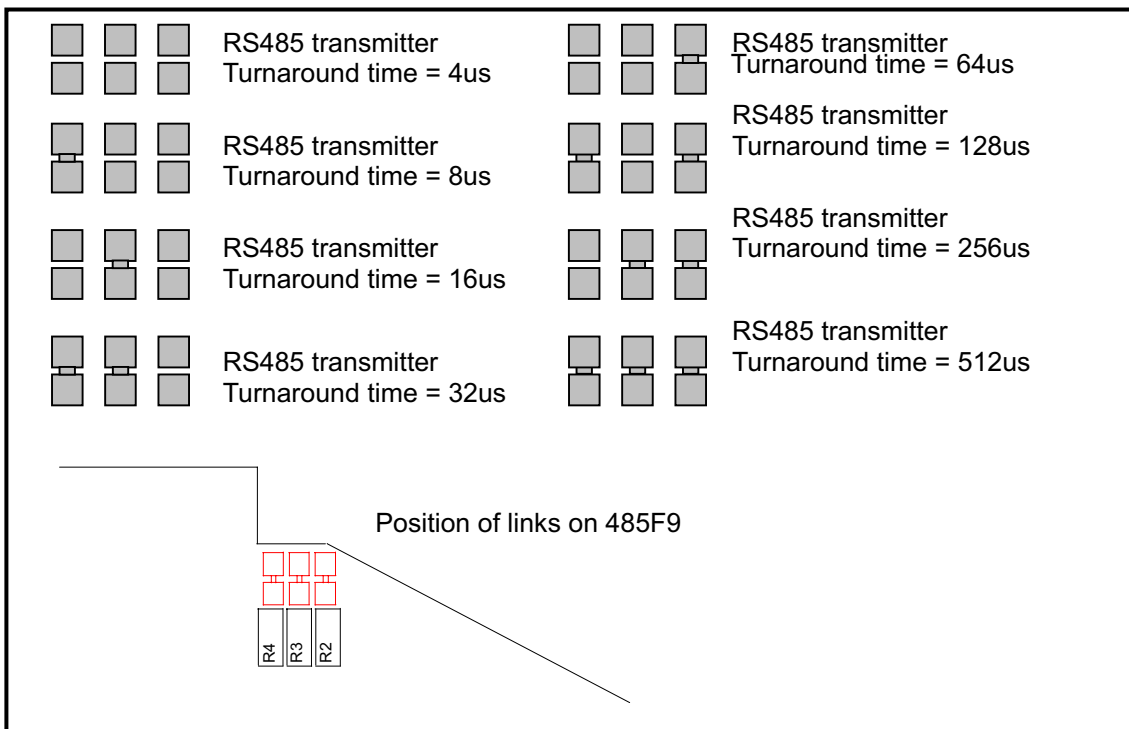

**485F9 LINK SETTINGS AND FUNCTION**