

# CMX-3510

Mounting Arrangement for Model 3510

**SENSOR**  
TECHNIQUES LIMITED

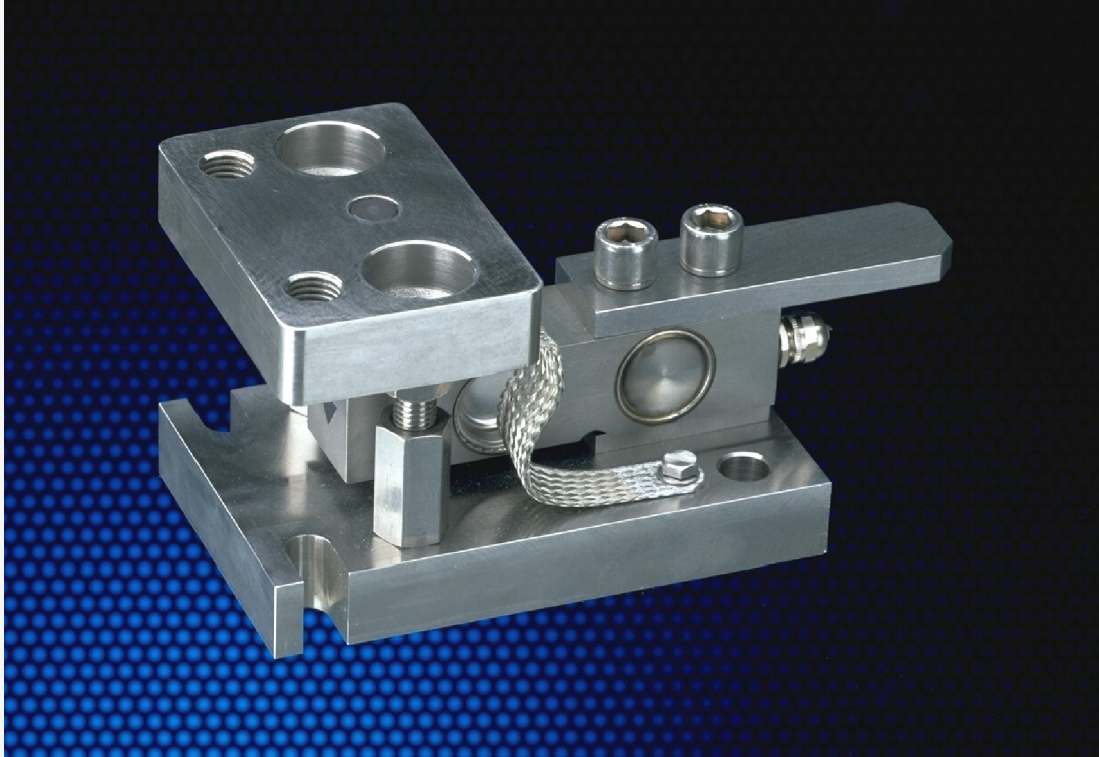

## Mounting Arrangement for Model 3510

- Self aligning, reduces the effect of side loads
- Ensures optimum performance from the load cell
- Suitable for use on capacity ranges up to 5000kg
- Ideal for tank and silo weighing
- Built-in jacking facility & lift off prevention
- Easy fitting & removal of the load cell
- Manufactured from stainless steel
- Integral cable protection plate

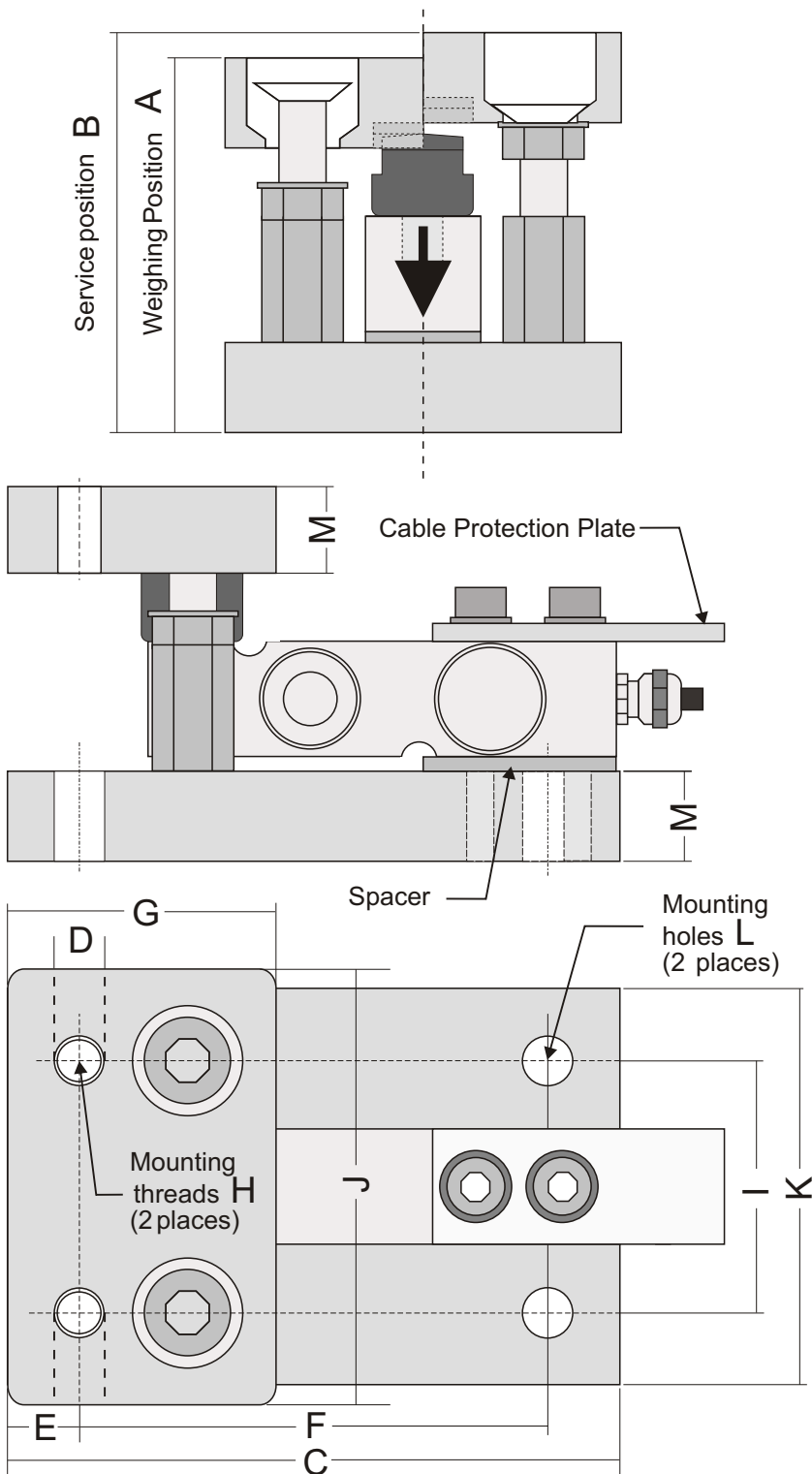

**Fitting Instructions**

- 1/ Ensure that the mounting arrangement is in the service position.
- 2/ Secure the mounting arrangement firmly to the installation. Make sure that all parts are level and aligned correctly.
- 3/ Remove the load cell mounting bolts and cable protection plate. Fit the load pillar into the 'live' end of the load cell and place the load cell complete with load pillar into mounting arrangement. Secure the load cell with the bolts provided.(finger tight)
- 4/ The top of the load pillar is rectangular in shape. This allows you to orientate the load pillar to take care of expansion in the installation (left to right or back to front). Align as appropriate.
- 5/ Before lowering the load onto the load cell, ensure that the load pillar arrangement is engaging correctly. Slowly and evenly, bring all the mounting arrangements into their weighing positions.
- 6/ Tighten the load cell mounting bolts to a recommended torque of 76Nm (56 lbs.ft.) for 500/1000/2000Kg capacities and 364Nm (268 lbs.ft.) for 5000Kg capacity
- 7/ For multi-cell applications,it is important to ensure that each loading point is evenly loaded. If this is not the case, shims can be placed between the mounting arrangement and the installation to correct this.

Model Number	A	B	C	D	E	F	G	H	I	J	K	L	M
CMX-3510	104	108	165	13.5	15	130	75	M16	70	110	100	14	24
CMX-3510-5t	137	143	216	17	20	162	90	M16	90	150	153	18	29

All Dimensions in mm  
 Specifications are subject to change without prior notice

DSCMX3510LP-2, 7/97



TECHNIQUES LIMITED

Tel. +44 (0)1446 771185 Fax +44 (0)1446 771186

Precision Load cells  
 Accessories and Mountings  
 Measuring Instruments and Systems