

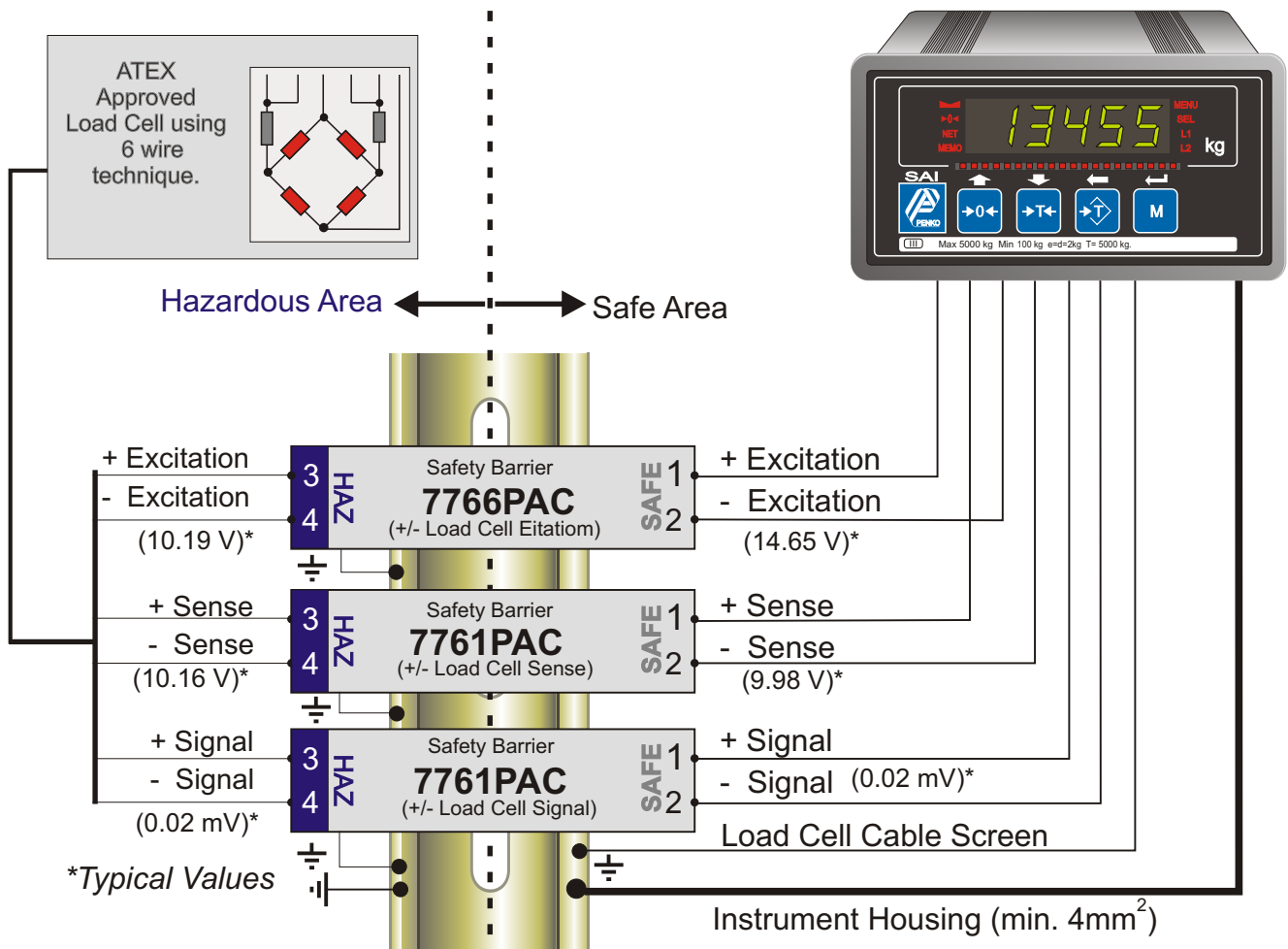

Electrical Safety Barriers Set for Weighing Applications

- For use with load cells working in Hazardous Areas
- Designed to live in the 'Safe' Area
- Limits energy available in the Hazardous Area
- Plug in screw terminal connections
- Din rail clip mounting
- Short circuit protected Zener Barrier
- Compact space saving construction



Specifications

All Dimensions in mm
Specifications are subject to change without prior notice

- Each kit consists of :- : 3 safety barriers, one each for load cell excitation, sense and signal. Designed for mounting on 35 mm 'Top Hat' Din rail. Removable terminal connectors. The barrier is automatically earthed when it is clipped onto the DIN rail.
- Max. End to End Resistance at 20°C : 7766Pac = 92 Ohm 7761Pac = 378Ohm
- Maximum Barrier Voltage : 7766Pac = 12V 7761Pac = 9V
- Minimum value of terminating resistor : 7766Pac = 75 Ohm 7761Pac = 350Ohm
- Maximum Short Circuit Current : 7766Pac = 157mA 7761Pac = 26mA
- Terminal Blocks : For cable diameters of up to 2.5mm², the removable terminals for the hazardous areas have blue labels
- Ambient Temperature : -20...+60°C continuous operation, - 40...+80°C storage
- Humidity : 5% to 95% relative humidity
- Weight per barrier : Approx. 140g
- Dimensions : 90 mm x 105 mm & 12.6 mm wide per barrier
- Ex Approval and Approval Number : II(1)GD [EEEx ia] IIC BAS01ATEX7217
- Other Standards : EN 50014 and EN50020

*Refer to manufacturer's instructions. Further information available on request.